

# CAVIUS

WIRELESS  
ALARM FAMILY  
**FLOOD**  
ALARM



**DANISH**  
**DESIGN**



**5 YEAR**  
BATTERY

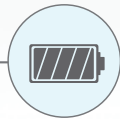

**100%**  
TESTED

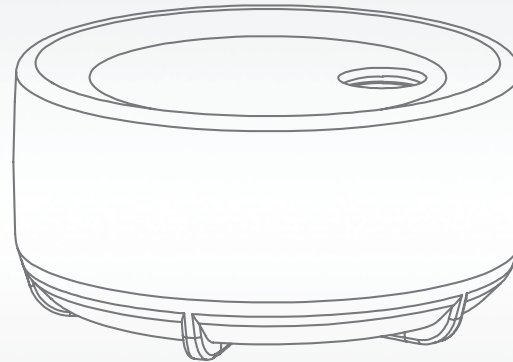

WIRELESS  
ALARM FAMILY

**FLOOD**  
ALARM





# CAVIUS

**PRODUCT NAME:** CAVIUS FLOOD/WATER ALARM, 5 YEAR 60MM

**PRODUCT NUMBER:** 5103

## PRODUCT DATA:

### DEVICE TYPE:

Water leakage alarm device with wireless interlink.

### USAGE:

Designed for installation in private homes, camping trailers, mobile homes and caravans. garages, humid environments such as kitchen or bathroom.

This alarm can be connected with other alarms from the CAVIUS Wireless alarm family or function as a stand alone alarm.

### FUNCTION:

Instant alarm at flooding.

### INSTALLATION POSITIONS:

Wall & floor.

### PRODUCT DIMENSIONS:

D: 60 mm. x H: 31 mm.

### PRODUCT WEIGHT:

Base alarm weight (excluding screws, plugs and mounting ring): 50 g.

### OPERATIONS AC/DC:

DC

### BATTERY TYPE:

3v CR123A lithium battery 1600mAh (replaceable).

### BATTERY LIFE:

Minimum 5 year life in normal operating condition. (Based on a weekly testing).

### POWER CONSUMPTION:

Battery consumption is 145mAh for 1 year in the non alarm condition.

### LOW BATTERY INDICATION:

A short acoustic "beep" will sound and LED flash every 48 seconds when the voltage is below 2.85V. In this stage it will continue for minimum 30 days, and can drive the alarm for 4 minutes.

### INTERLINK FREQUENCY:

868MHz

### SIGNALS:

Transmits RF signals to the CAVIUS Wireless Family at alarm.

### NORMAL OPERATION:

LED flashes every 48 second for normal operation.

### INTERLINK RANGE:

Minimum 100m in open field. Range depends on the building materials and will need to be tested in each individual case.

### SOUND:

Audible indicator min. 85 dB @ 3 meter in anechoic chamber.

### SOUND PATTERN:

Flood alarm condition is indicated by a sweeping sound.

### VISIBLE INDICATOR:

A red LED is used to indicate the following conditions:

- alarm condition is indicated by a flash every 0.5 seconds
- normal operation is indicated by a flash every 48 seconds

### PUSH BUTTON:

The flood alarm includes a push button switch built into the top of the alarm for easy access. This button has the following functions:

- set up - press the button to start sending out a specific house code to the others alarms
- hush – during an alarm condition this immediately silences the alarm when pressed. When the button is released, the alarm remains silenced for 10 minutes
- test – when not in alarm the sounder can be activated to provide a sensor OK test function. While the button is pressed, the audible and visible indicators are activated if the sensor is OK



**PRODUCT NAME:** CAVIUS FLOOD/WATER ALARM, 5 YEAR 60MM

**PRODUCT NUMBER:** 5103

## PRODUCT DATA:

### DETECTION TIMING:

Instant detection when flooding.

### WARRANTY:

10 year

### APPROVALS:

EN60065  
RED  
RoHS  
REACH

### CE TESTING INSTITUTE:

CNPP

### ADDITIONAL TESTING AND APPROVALS:

SGS (RF Approval)

### AWARDS:



reddot design award  
winner

### ASSOCIATIONS AND COMMITTEES:

CAVIUS is member of the NF292 committee.

CAVIUS is member of GIFSID, manufacturers' association  
of domestic fire safety equipment.

### OPERATING TEMPERATURE:

+4°C to +38°C (tested from 0 degrees to 55 degrees)

### OPERATING HUMIDITY:

Up to 90% RH non-condensing

### STORAGE TEMPERATURE:

-20°C to +60°C

### STORAGE HUMIDITY:

Up to 93% RH non-condensing

## QUALITY ASSURANCE:

### SOUND LEVEL:

100% tested in special designed sound chamber.

### SENSITIVITY:

100% tested

### POWER CONSUMPTION:

100% tested

### BATTERY VOLTAGE AND INTERNAL RESISTANCE:

100% tested

### ALARM FUNCTION:

100% tested

### INTERCONNECTION:

100% tested

### VISUAL APPEARANCE:

100% tested

### PACKING CONTENT:

100% tested

## CONTACT

[www.cavius.com](http://www.cavius.com)

## MANUFACTURER

Manufacturer: CAVIUS Aps, DK8260

# CAVIUS

WIRELESS  
ALARM FAMILY

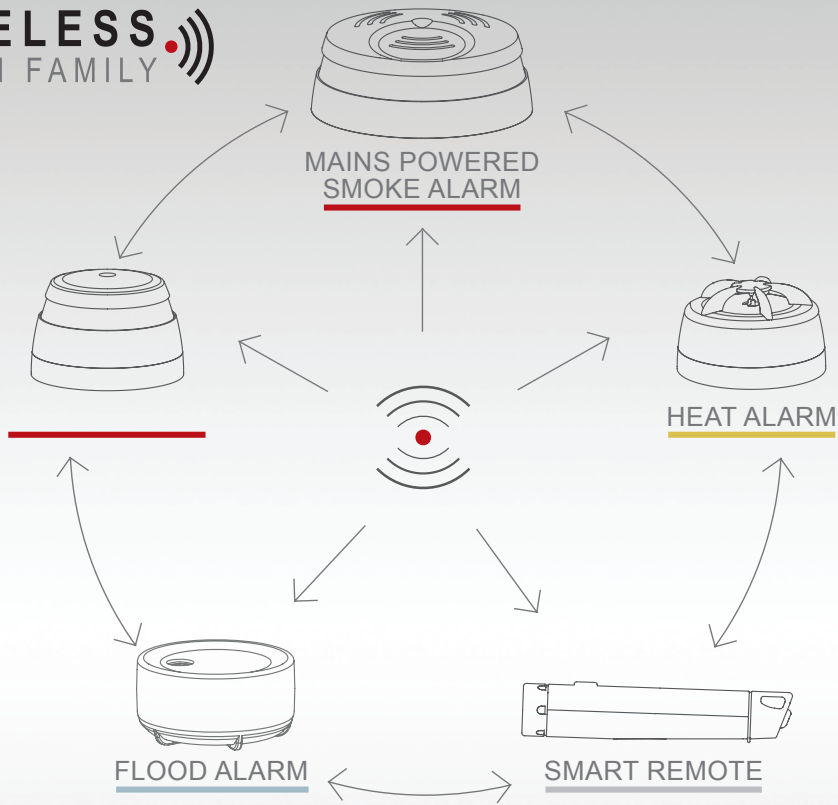

Diameter: 60 mm

PRODUCT NAME: CAVIUS FLOODWATER ALARM, 5 YEAR 60MM

PRODUCT NUMBER: 5103

DISTRIBUTOR:

